

APPLICATION:

Silos, deposits, multi-cell scales & weighbridges

CAPACITY RANGE:

150kg - 300kg - 500kg - 1t - 2t* - 3t*
5t* - 7t* - 10t* - 20t - 30t

MATERIAL:

Stainless Steel

ENVIRONMENTAL PROTECTION:

IP68

***APPROVALS: from 2t until 10t**

CE 3000 Div - TC8829

OIML 3000 Div - R60/2000-NL 1-16.09

CHARACTERISTICS

Construction using stainless steel.
The laser soldered closing protects from the typical environment in food and chemical industry.
Mounting compatibility.

APPLICATIONS

The CRI model is manufactured to maintain its performance capabilities in the environmental conditions existing in industries, where tasks and cleaning demand a good environmental protection.

OPTIONS

Length of the cable is optional.

Hostile environmental cable.

ATEX option

EC-Type examination certificate

CEC 11 ATEX 040 X according directive 94/9/EC

 II 1G EExia IIC T6 (Ta-0÷+40°C)
TX (Ta-20÷+65°C)

 II 1D tD A20 TX°C (Ta-20÷+40°C)
TX°C (Ta-20÷+65°C)

For more information look up the EC-type examination certificate, and documentation.

Consult for special requirements.

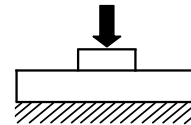

TEFLÓN® protects all the internal cables

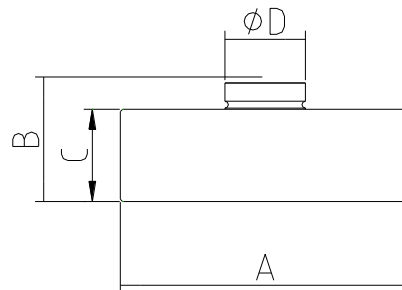

Capacity (t)	ØA	B	C	ØD
0.150 to 10	82	44	32	22
20/30	128	54	40	35
50	128	54	40	35

Dimensions in mm

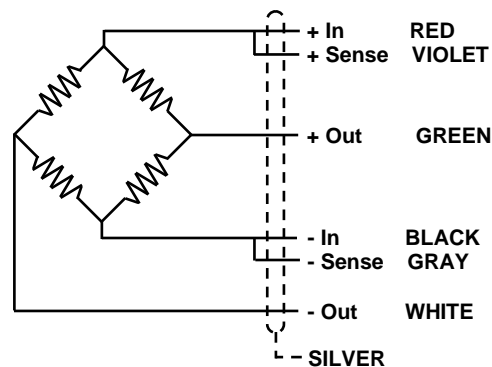

GENERAL TECHNICAL CHARACTERISTICS FOR $g = 9,8031 \text{ m/s}^2$

OIML Class	C2 & C3	UNITS
Divisions n_{LC}	2000 & 3000	
Minimum Dead load E_{min}	0	kg
$Z = E_{max} / 2DR$	2000 & 3000	
$Y = E_{max} / V_{min}$	10000	
V_{min}	$E_{max} / 10000$	
Rated Capacity E_{max}	150 - 300 - 500 - 1000 - 2000 3000 - 5000 - 7000 - 10000 - 20000 30000 - 50000	kg
Rated Sensitivity C	$2 \pm 0,1 \%$	mV/V
Rated Input Voltage	10	V dc
Input Voltage Range	5...15	V ac/dc
Input Resistance R_{LC}	$1100 \pm 10\%$	Ω
Output Resistance	$1000 \pm 10\%$	Ω
Zero Balance	± 2	% E_{max}
Insulation Resistance at 50 V DC	> 5000	M Ω
Service Overload	> 150	% E_{max}
Elim.	> 300	% E_{max}
Temperature Range : Compensated	- 10 ... 40	$^{\circ}\text{C}$
: Operating	- 30 ... 85	$^{\circ}\text{C}$
: Storage	- 30 ... 90	$^{\circ}\text{C}$
Max. Non-linearity	0,025	% E_{max}
Max. Hysteresis	0,015	% E_{max}
Max. No repeatability	0,01	% E_{max}
M Max. Creep in 4 hours	0,03	% E_{max}
Max. Zero Recovery Test in $\frac{1}{2}$ hour	0,007	% E_{max}
Max Temperature effect : On Sensitivity	0,0013	% $E_{max} / ^{\circ}\text{C}$
: On Zero	0,001	% $E_{max} / ^{\circ}\text{C}$
Weight	600 - 1300	g
Cable Length	5 (0,1 to 10t) / 15 (20 to 50t)	m
Environmental Protection	IP68 - DIN 40050 (100h 1m)	



Ref: 491046
Ref: 491055 (S. Steel)
0,5t to 10t



Ref: 491047A
0,5t to 10t



Ref: 491049
Ref: 491048 (S. Steel)
20t to 30t